

Structural Equation Modeling with AMOS

Petri Nokelainen

petri.nokelainen@tuni.fi

Introduction.....	1
Sample data.....	1
Data prerequisites.....	3
Exercise 1: Path analysis.....	5
Exercise 1a.....	9
Exercise 1b.....	10
Exercise 2: Latent variable model.....	11
Exercise 2a.....	26
Exercise 2b.....	29
References.....	31

Introduction

This learning material is a tutorial that shows how to design and analyze path (observed variables) and structural equation (latent variables) models (for more details, see Nokelainen & Ruohotie, 1999). This material supports the lectures (<http://butler.cc.tut.fi/~nokelaip/mmx9120>) and research literature (Arbuckle & Wothke, 1999; Bollen, 1989; Byman, 2003; Kaplan, 2000). We use here an AMOS (Analysis of Moment Structures) program developed by James Arbuckle (<http://www.spss.com/amos>), but these exercises work naturally also with other SEM programs, such as LISREL (<http://www.ssicentral.com/lisrel>), MPLUS (<https://www.statmodel.com>, Muthen & Muthen, 2000), EQS (<http://www.mvsoft.com>) and various R sem packages (e.g., lavaan, <http://lavaan.ugent.be>).

Sample data

Our sample material consists of two sub samples that are collected from Finnish polytechnics of higher education in 2000 ($n = 447$, 'data1.sav') and 2003 ($n = 332$, 'data2.sav'). The respondents in both samples are the staff of the organizations (e.g., leaders, teachers, clerks, cleaners, etc.). The original measurement instrument (Growth-oriented Atmosphere Questionnaire, GOAQ) has 13 factors and 92-items (Ruohotie, 1996; Ruohotie, Nokelainen & Tirri, 2002), but for the purposes of this exercise I have selected the following factors and sample items (see Table 1). Five –point Likert scale from 1 (totally disagree) to 5 (totally agree) was applied.

Table 1. Growth-oriented Atmosphere Questionnaire items (Ruohotie, 1996; Ruohotie, Nokelainen & Tirri, 2002; Nokelainen & Ruohotie, 2009)

Factor 1: Encouraging leadership (ENC)

My manager is friendly and easily approachable.
 My manager pays attention to my suggestions and wishes.
 My manager works with a team to find solutions.

Factor 3: Know-how rewarding (REW)

It is rewarding to achieve my goals.
 The organization rewards its employees' professional knowledge and skills.
 Employees with increased knowledge are given extra responsibility.

Factor 5: Incentive value of the job (INV)

I can work independently and without restrictions.
 I can use my skills at work in a variety of ways.
 My work consists of various differing tasks.

Factor 6: Clarity of the job (CLA)

A clear division of tasks exists between members of teaching staff.
 The organization's decision making structure is transparent.
 The organization's goals are transparent.

Factor 7: Valuation of the job (VAL)

My manager appreciates my work.
 I am given encouraging feedback on my work.
 I feel that my work is valued.

Factor 10: Psychic stress of the job (PSY)

I feel that I am beginning to dislike my work.
 I feel that it is getting more difficult for me to take the initiative.
 I find it difficult to concentrate.

Factor 11: Build-up of work requirements (BUI)

My workplace has too few employees to cope with the workload.
 My workload has increased during the past years.
 My working pace has increased in recent years.

Data prerequisites

The sample data for this exercise (“data1.sav”) is downloadable from:

http://butler.cc.tut.fi/~nokelaip/mmx9120/2_sem/exercises/amos/data.

The data is in SPSS (*.sav) format, as we first examine its technical properties for structural equation modeling. AMOS is able to read SPSS data as an input. For the other software packages mentioned earlier, the data must be saved into a different format. Usually all programs are able to read tabulator delimited text files (In SPSS: File - Save As - Tab delimited *.dat).

1. Download and save the “**data1.sav**” file into your computers temporary file folder's sub folder "sem_data" (e.g., c:\temp\sem\).
2. Open the data with SPSS and examine if all the variables meet the *univariate* normal distribution (a variable is normally distributed, if its graphical shape follows 'bell curve') assumption (In SPSS: Analyze - Descriptive Statistics - Frequencies, Charts -> Histograms with normal curve). Note that both the shape of the phenomena under investigation and its operationalizations (the data) shape must resemble each other.

- Are there any variables that meet the univariate normal distribution assumption?

--	--	--	--	--	--	--	--	--	--

- Are there any variables that *do not* meet the univariate normal distribution assumption?

--	--	--	--	--	--	--	--	--	--

3. Examine if two variables that meet the univariate normal distribution (UND) assumption also meet the *multivariate* normal distribution assumption by plotting them together (a statistical dependency between two variables must be linear, in SPSS: Graphs - Interactive - Dot).

- How the different type of variable pairs meet the multivariate normal distribution assumption?

Both meet the UND assumption	One is UND, the other is not UND	Neither is UND
_____ & _____	_____ & _____	_____ & _____
linear / non-linear	linear / non-linear	linear / non-linear

4. Examine the correlation matrix (Table 3). Usually, correlations between +/- .3 - .9 are considered usable in multivariate analysis. Too low correlations indicate weak inter-item dependency, too high correlations might indicate multicollinearity.

Exercise 1: Path analysis

In this exercise, we will build a model of observed variables (path analysis). The statistical calculations are based on multiple linear regressions. These calculations do not need a special program like AMOS, but it allows an easy way of building the model visually, instead of programming by hand series of regression analyses in SPSS.

The model that we build here examines four predictors (IV's) of valuation of the work (DV). The predictors are: Encouraging leadership, Know-how rewarding, Incentive value of the job, Clarity of the job. (Figure 2).

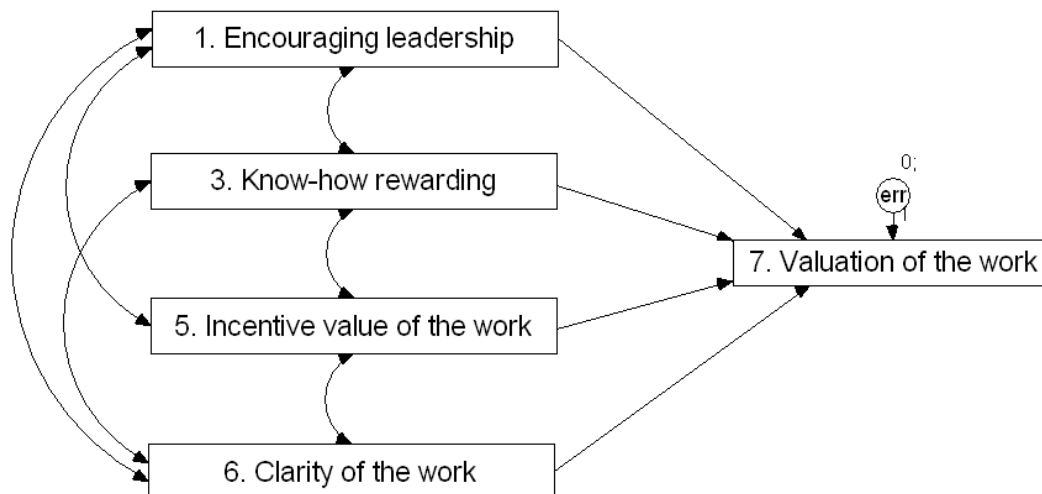
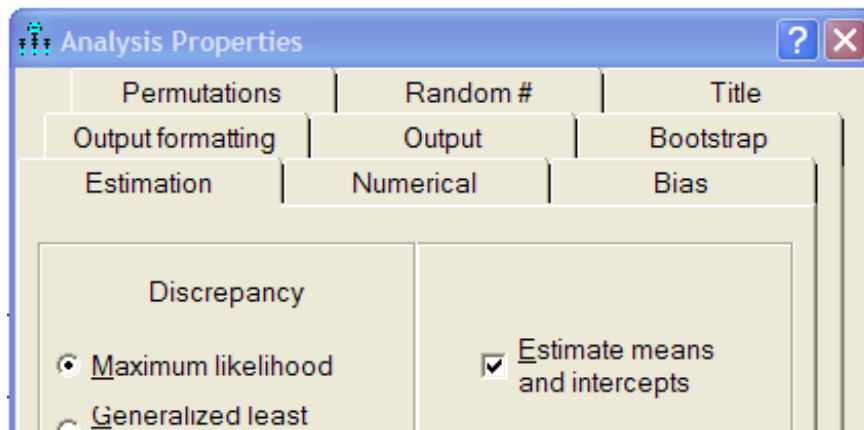

Figure 1. Predictors of valuation of the job in Finnish polytechnic institute of higher education (path model 2)

1. Go to http://butler.cc.tut.fi/~nokelaip/mmx9120/2_sem/exercises/amos/data folder and save the “data1factors.sav” file to your working computer’s hard drive (e.g., c:\temp\sem).

The data consists of the thirteen growth-oriented atmosphere factors (means of the items specified in Table 2). The sample is the same as in data1, 447 staff members of Finnish polytechnic institute for higher education. The sample was collected in 2000.



2. Select **File -New**.
3. Select **File -Data Files**.
4. Click the **File Name** button and select the “data1factors.sav” file.
5. Check that the **N** column reads 447/447 and click the **OK** button.
6. Select **View/Set – Interface Properties** and click the **Page Layout** divider.
7. Choose **Orientation: Landscape** and click the **Apply** button.
8. Close the **Interface Properties** window.
9. Select **View/Set – Analysis Properties** and activate the **Estimation** divider.
10. Select **Estimate means and intercepts**.



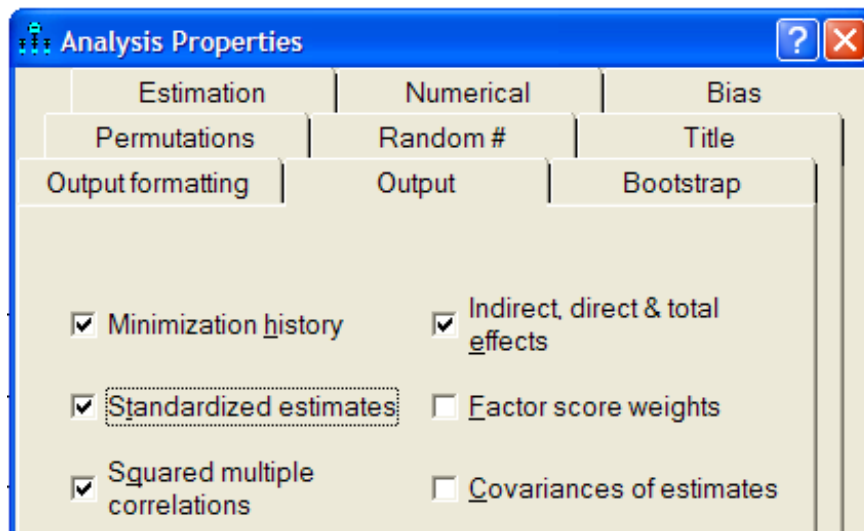

11. Activate the **Output** divider and select **Standardized estimates, Squared multiple correlations** and **Indirect, direct & total effects**.

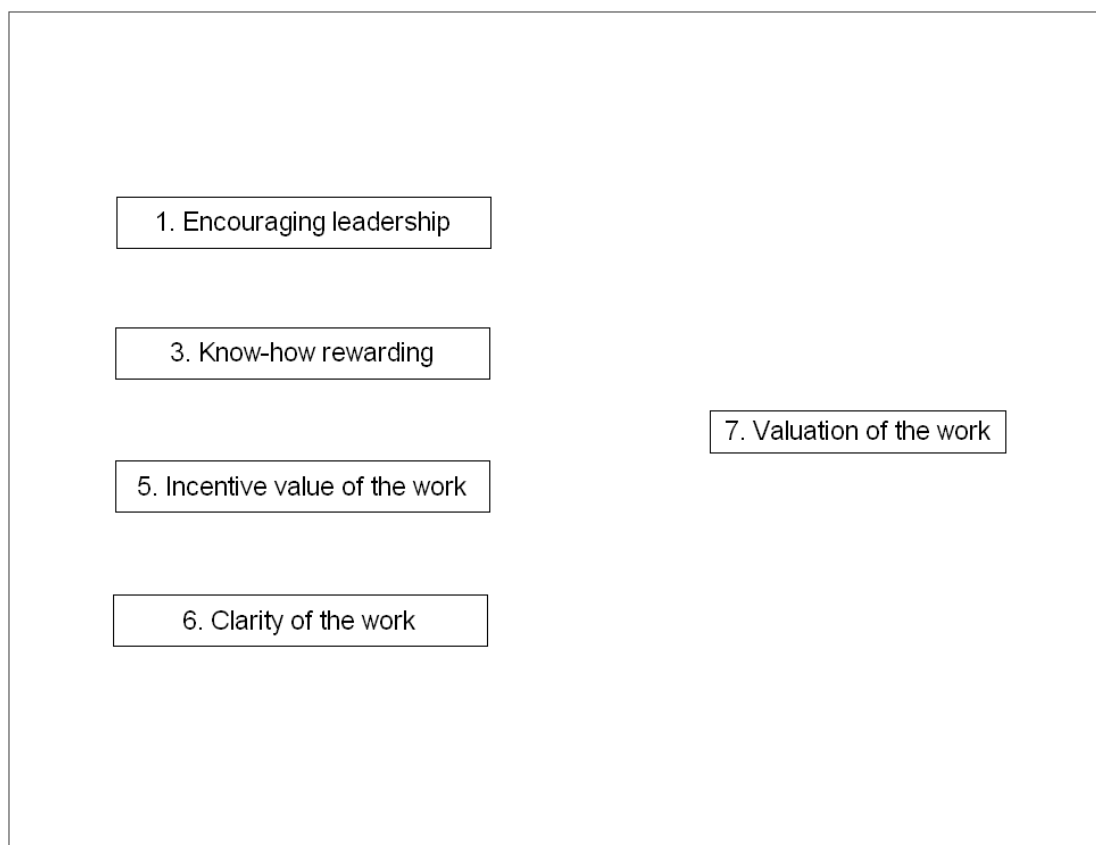

12. Close the **Analysis Properties** window.
13. Save the model as “**data1factors_1.amw**”.
14. Select **View/Set – Variables in Dataset**.
15. Drag the four IV and one DV variable from the **Variables in Dataset** window to the drawing area:

In order to make the rectangles the same size, you can use the **Change the shape of objects** tool  after selecting all the objects (with ) that you wish to reshape.



16. Add an error term to the DV variable with **Add a unique variable**  button.

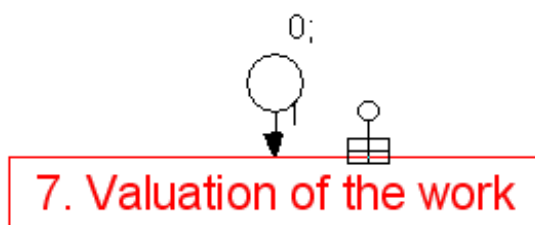
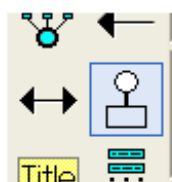

17. Double click inside the error term circle and name it as "err".

18. Add covariance (between IV's) and variance arrows (from each IV to the DV) to the model:

In order to draw the covariances easily, *first* select all IV's and *then* use **Tools – Macros – Draw covariances**. (AMOS version 16: **Plugins – Draw covariances**)

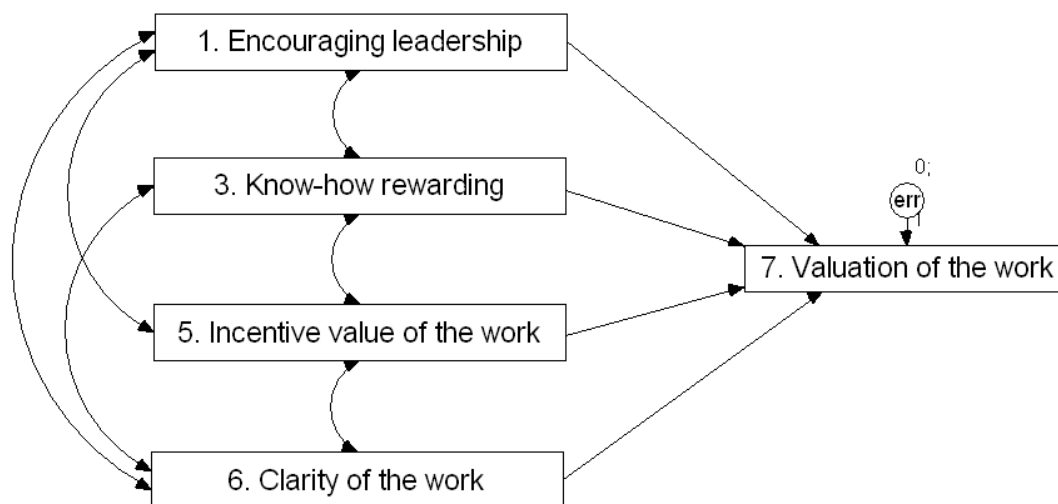

19. Click the **Calculate estimates (Ctrl+F9)** button  to perform the analysis of the model with the data.

20. Click the **View the output path diagram** button  to see the results of the analysis.

21. Select *Standardized estimates* and answer to the following questions:

a. How much DV's variance the four IV's predict? $S_{mc} = \underline{\hspace{2cm}}$, $\underline{\hspace{2cm}}$ %.

b. Order the IV's in the following rows (best predictor comes first):

○ The first (strongest) predictor for *Valuation of the work* is
 _____ $r = \underline{\hspace{2cm}}$

○ The second predictor for *Valuation of the work* is
 _____ $r = \underline{\hspace{2cm}}$

○ The third predictor for *Valuation of the work* is
 _____ $r = \underline{\hspace{2cm}}$

○ The fourth predictor for *Valuation of the work* is
 _____ $r = \underline{\hspace{2cm}}$

22. Select *Unstandardized estimates* and complete the following sentences:

○ When *Encouraging leadership* goes up by 1, *Valuation of the work* goes up / down by _____.

○ When *Know-how rewarding* goes up by 1, *Valuation of the work* goes up / down by _____.

Exercise 1a

1. Save the “**datafactors_1.amw**” model as “**datafactors_2.amw**”.
2. Modify the “**datafactors_2.amw**” model as follows:

We add in this exercise an indirect path from *Know-how rewarding* via *Incentive value of the work* to *Valuation of the work*.

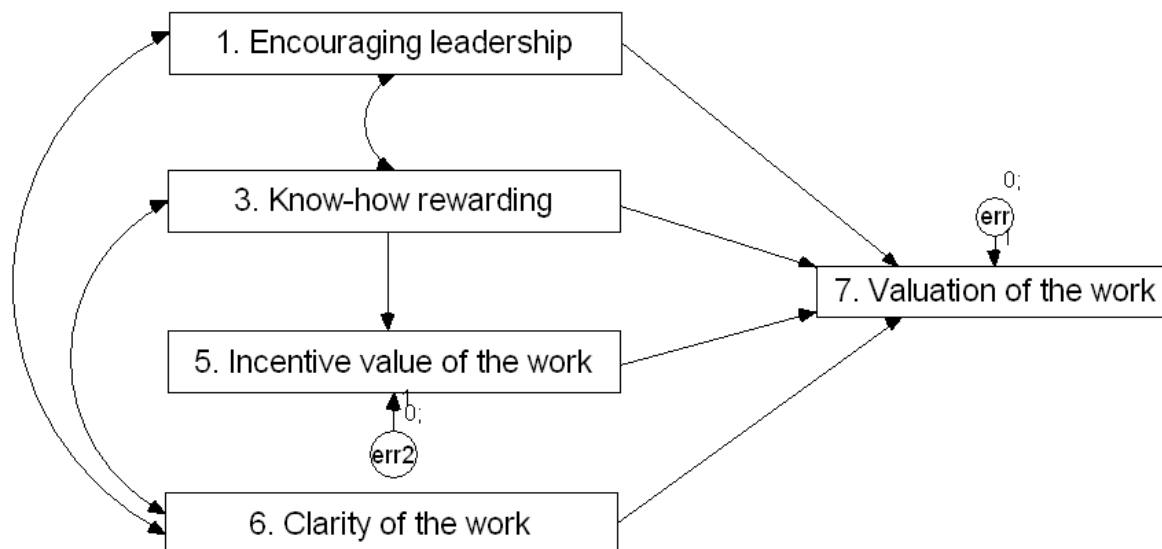

3. Calculate the estimates and answer to the following questions:
4. How much DV's variance the four IV's predict? $S_{mc_{model_1}} = \underline{\hspace{2cm}}, \underline{\hspace{2cm}} \%$.
 - Compare this finding to the previous model's smc: $S_{mc_{model_2}} = \underline{\hspace{2cm}}, \underline{\hspace{2cm}} \%$.
 - How does the indirect path affect the regression model?

Exercise 1b

1. Go to http://butler.cc.tut.fi/~nokelaip/mmx9120/2_sem/exercises/amos/data data and save the “**data2factors.sav**” file to your working computer’s hard drive (e.g., c:\temp\sem).

This data2factors shares the same variable structure with data1factors, but is collected from another Finnish polytechnic institute for higher education in 2003 ($n = 332$)

2. Open the “**data1factors_1.amw**” model and save it as “**data2factors_1.amw**”.
3. Select **File -Data Files**.
4. Click the **File Name** button and select the “**data2factors.sav**” file.
5. Check that the **N** column reads 332/332 and click the **OK** button.
6. Calculate the estimates.
7. Ponder if the model is generalizable over the two samples (i.e., are the results comparable)?
 - $S_{mc}^{\text{data1factors}_1} = \text{_____}, \text{_____} \%$, $S_{mc}^{\text{data2factors}_2} = \text{_____}, \text{_____} \%$.

Exercise 2: Latent variable model

Our first task is to build a latent variable model that is presented in Figure 1. The model examines how *encouraging leadership* and *build-up of work requirements* together affect on *psychical stress of the work*. Standardized estimates are presented.

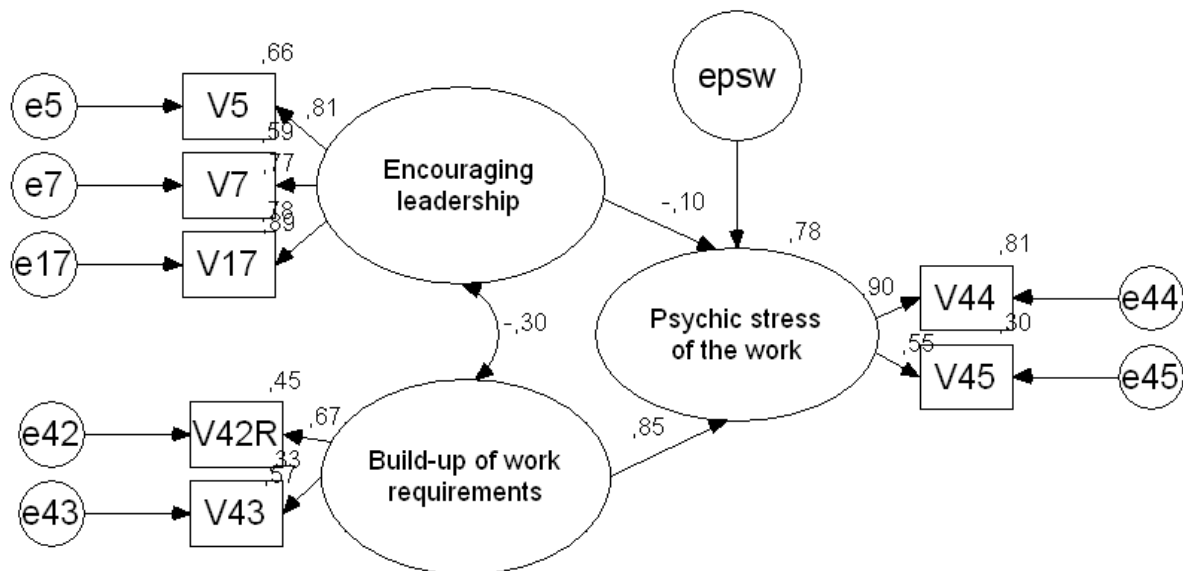

Figure 1. Predictors of psychic stress of the work in Finnish polytechnic institute of higher education (structural equation model 1)

1. Go to http://butler.cc.tut.fi/~nokelaip/mmx9120/2_sem/exercises/amos/data folder and save the “**data1.sav**” file to your working computer’s hard drive (e.g., c:\temp\sem).

The data file ($n = 447$) is collected in 2000 from Finnish polytechnic for higher education staff and includes their answers to 22 growth-oriented atmosphere questions (Table 2).

2. Open AMOS Graphics.
3. Choose **File - Data Files**.
4. Click **File Name** button and open the “**data1.sav**” file that is located in your computer.
5. Check that the N column shows 447/447 and click the **OK** button.
6. Save the model with the **File – Save As ..** (Ctrl + S) command to your work folder using name “**data1_1**”.

AMOS will add a **.amw** ending to the given file name (“**data1_1.amw**”). It is a good habit to save the model quite often to prevent data loss should your computer crash.

7. Select **View/Set – Interface Properties** and click the **Page Layout** divider.
8. Choose **Orientation: Landscape** and click the **Apply** button.
9. Close the **Interface Properties** window.
10. Choose **Estimation** divider from **View/Set – Analysis Properties** window.
11. Select **Estimate means and intercepts**:

This selection allows missing values.

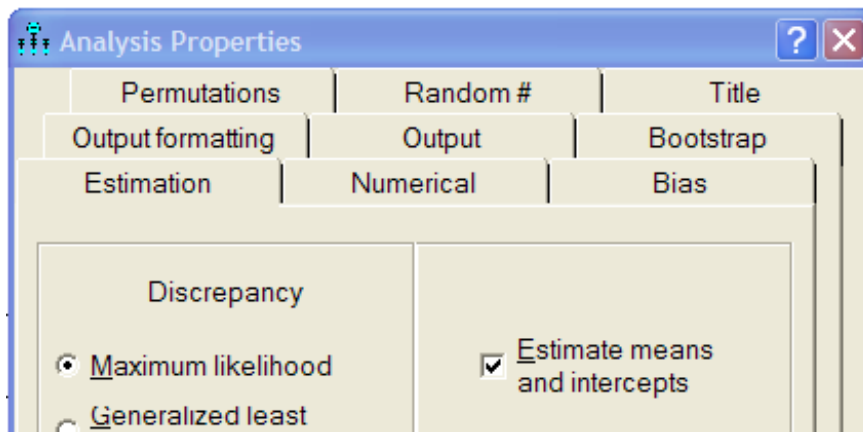

12. Choose **Output** divider and select **Squared multiple correlations, Standardized estimates and Indirect, direct & total effects**.

Squared multiple correlations (smc) show how much the IV variables explain the variance of the DV variable.

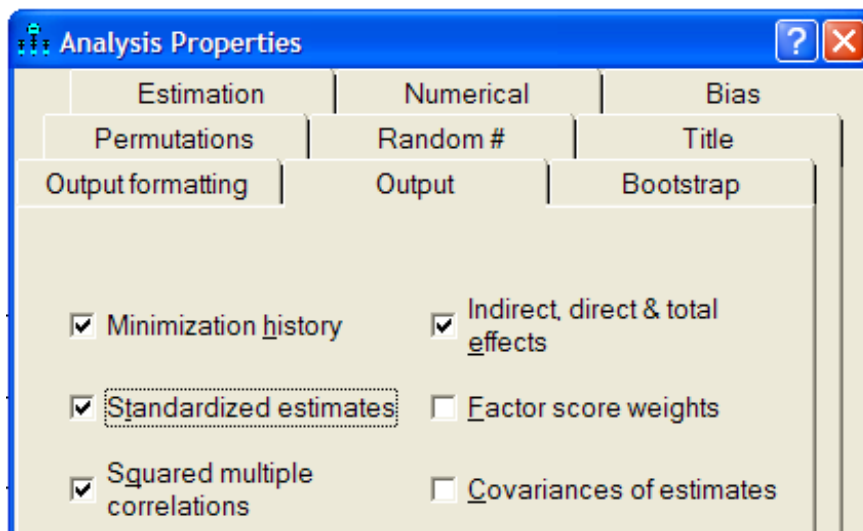

13. Close the **Analysis Properties** window.
14. Select the **Draw unobserved variables (F4)** tool.

Note that the AMOS toolbar works like an old radio that has push buttons: You select a tool by clicking its button (icon) once, and deselect the tool by clicking the same button once again. No mouse dragging *from* the toolbar to the drawing area is needed, but most of the drawing tools assume that you specify the size of the object by mouse dragging *inside* the drawing area.

15. Draw an ellipse with the tool on the drawing area by dragging with your mouse.

Note that Ctrl+Z (UNDO) works with AMOS, too. See Figure 1 for a location hint, remember that we are building a similar model!

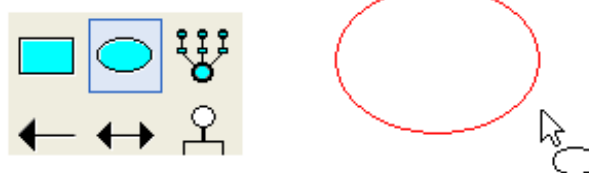

16. Select **Draw a latent variable ...** tool and click *inside* the ellipse you just draw *three times*.

Now you have specified the first latent variable in Figure 1 ("Encouraging leadership") and three observed variables, that is, three questions in the questionnaire ("v5", "v7" and "v17", see Table 1 for details).

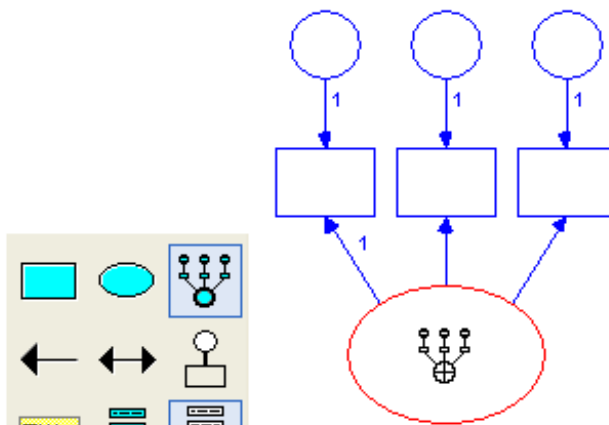

17. Select the **Rotate** tool  and click inside the ellipse as many times as needed to rotate the group of three observed variables to the left-hand side of the latent variable:

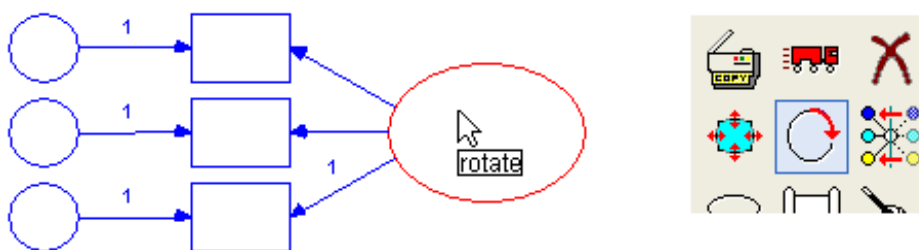

18. Click **Select All Objects** button  in the toolbar.

Note that all selected objects in the drawing area are colored **blue**.

19. Click **Move objects** button  and drag all the selected (i.e., blue) objects to the upper left hand part of the drawing area:

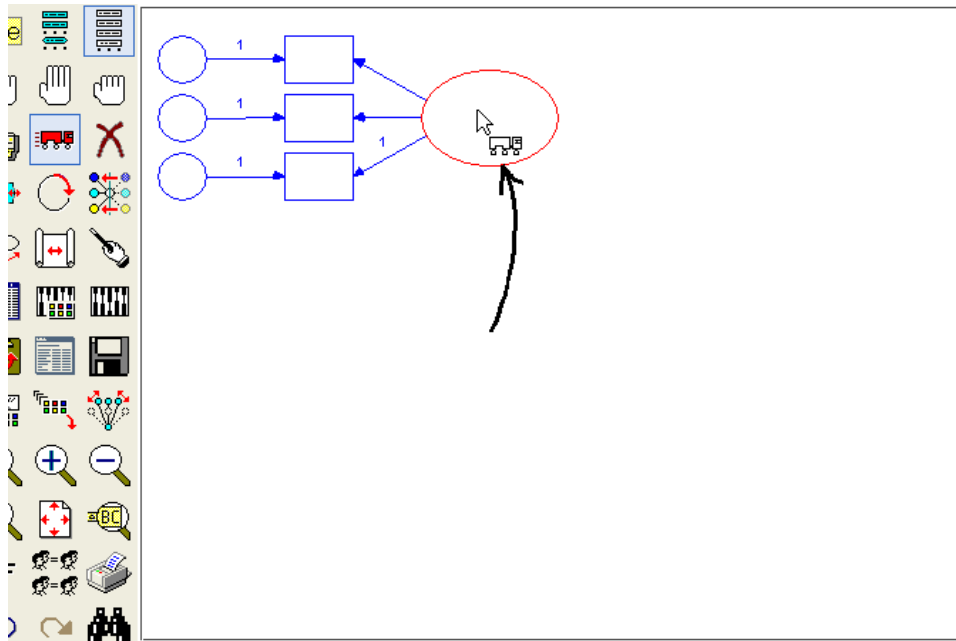

20. Click **Duplicate objects** button  on and start dragging *inside* the ellipse towards the lower part of the drawing area:

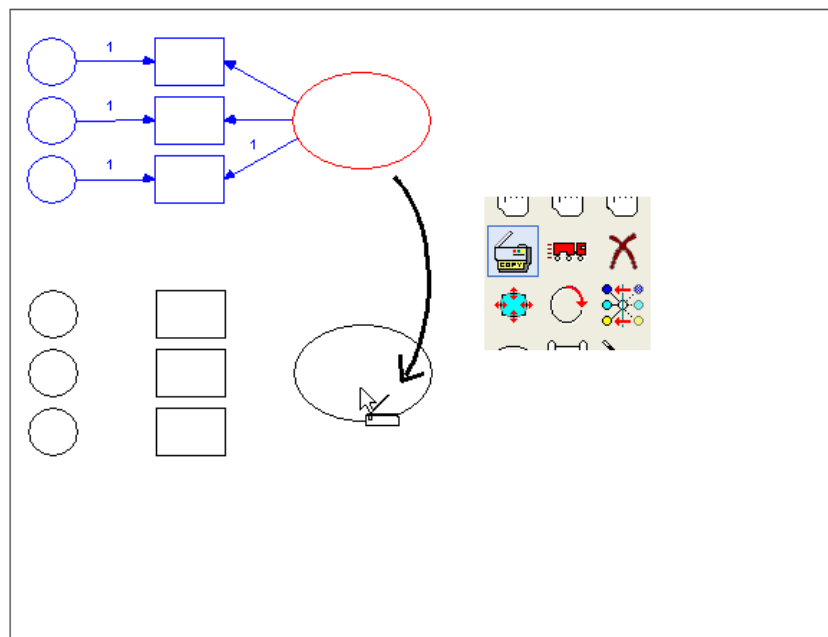

Turning something *on* means that the button is on downwards position, i.e., the button is pressed down



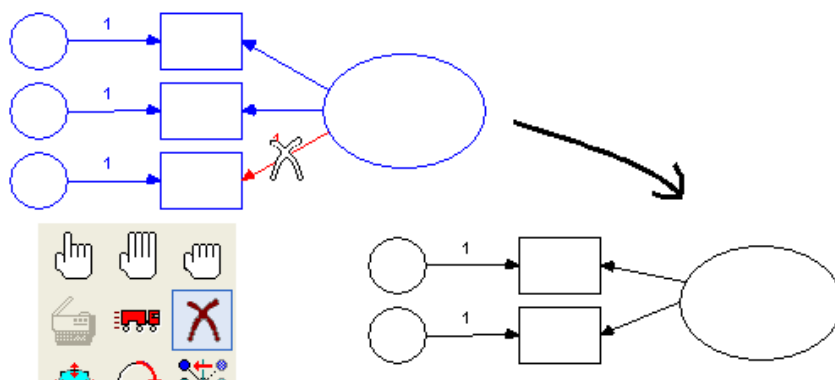

21. Use the **Delete** button  to remove the lowest observed variable (and its error) from the copied latent variable.

The reason for doing this is simply that if we aim to build a model according to the Figure 1, we only need two observed variables for the last two latent variables.

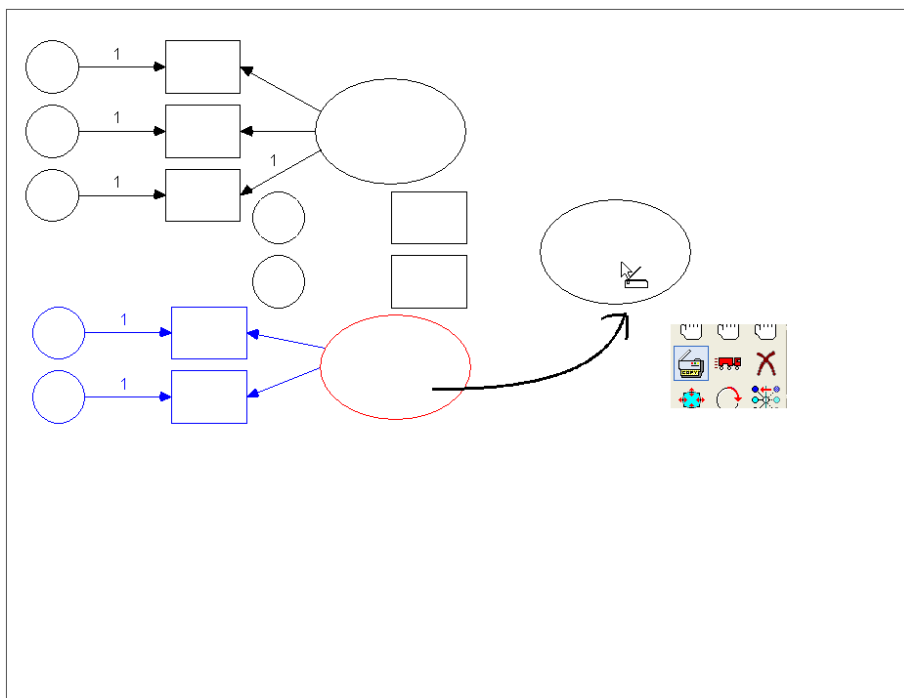

22. Click the **Deselect all objects** button  to make sure that nothing is selected.
23. Click the **Select one object at a time** button  to select all components of *the second latent variable cluster* (this means that you need to click everything in the cluster to make it “blue”).
- The first latent variable cluster will stay “black” and the new copy of it (except that the copy has one observed variable less) becomes “blue”.
24. Repeat the duplication procedure for the third (and last) latent and observed variable cluster in the model. It is wise to duplicate the selected (“blue”) cluster, as it already has the right number of observed variables.



20. Use the **Rotate** tool  to adjust the two observed variables to the right hand side of the third latent variable.
21. Click the **Resize the path diagram ..** tool button  to fit all the objects on the drawing area.
22. Now we have defined the templates for all three variable clusters: “kj_enc1”, “tv_bui12” and “tr_psy11”. The model should look like this:

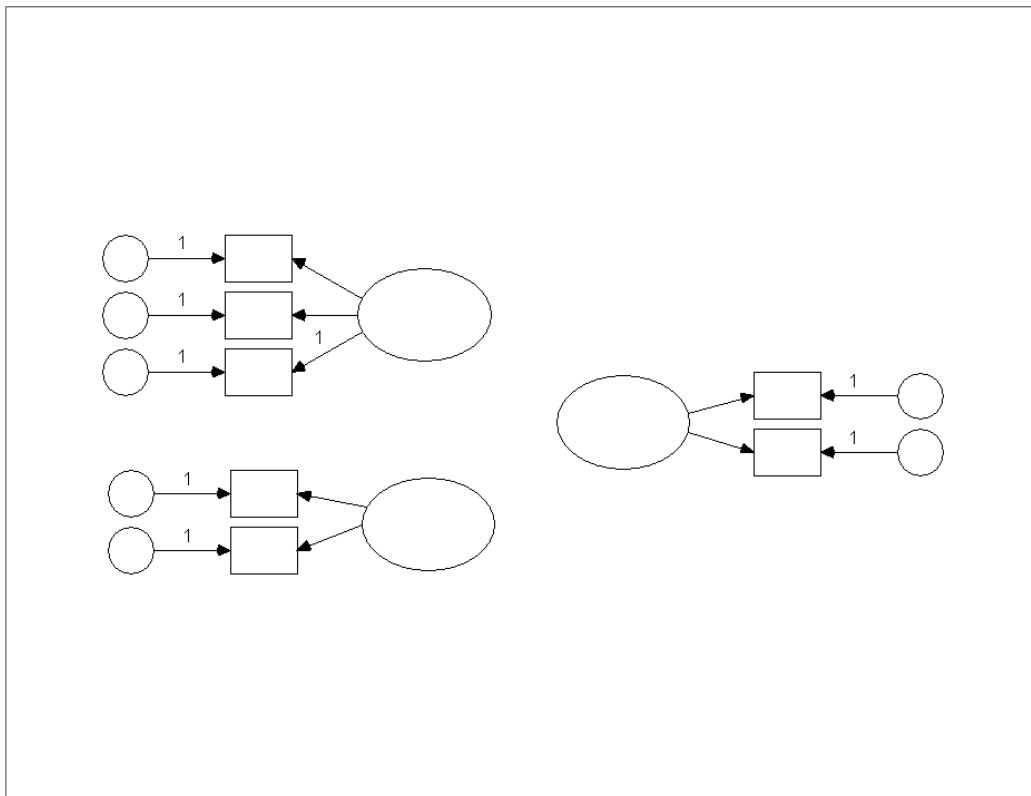

23. Select **View/Set – Variables in dataset**.

24. Click the **Deselect all objects** button  to make sure that nothing is selected.

If several objects are selected, in the next step (dragging of variables from the list to the model) each dragged variable would “fill” all selected (blue) observed variable rectangles – and that is something that we do not wish to do!

25. Drag the observed variables into their right places (see Figure 1):

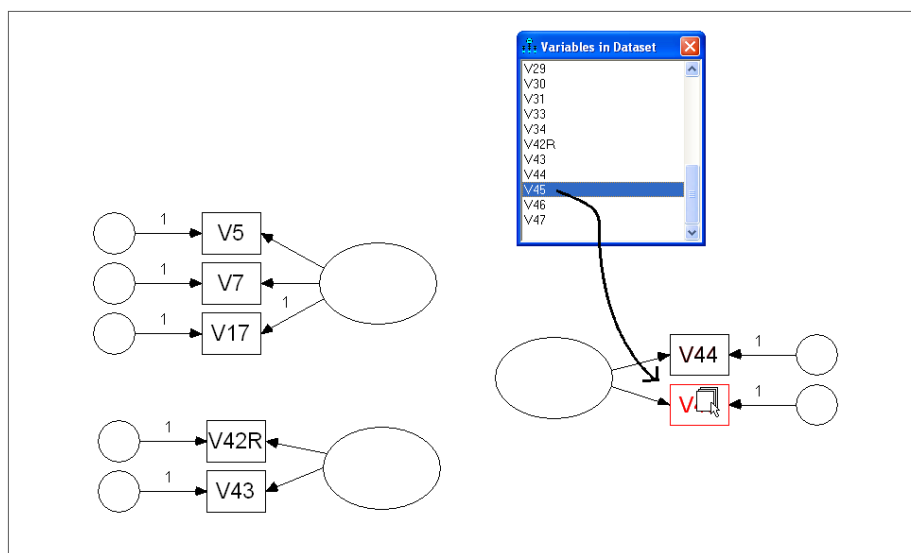

26. Close the **Variables in dataset** window.

27. Double click (AMOS 16: Right mouse click) on the uppermost left latent variable ellipse to open the **Object properties** window.

28. Select the **Text divider** (if not selected) and write "Encouraging [ENTER] leadership" on the **Variable Name** field (DO NOT use the **Variable label** field):

If the text is too big to fit into the ellipse, adjust the text size in the **Font size** field of the **Object Properties** window *or* resize the ellipses with the **Change the shape of objects**

tool .

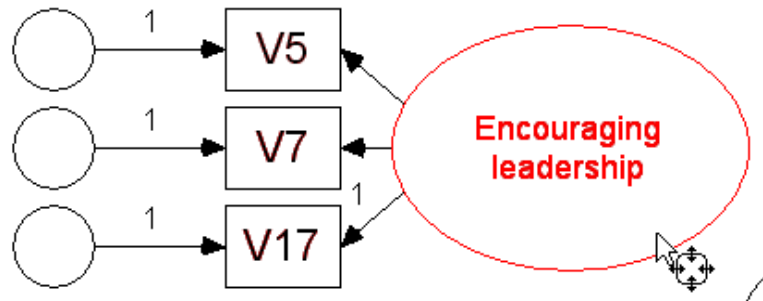

29. Click on the other two latent variable ellipses and feed the requested variable name information into them (lowest left latent variable: "Build-up of work [ENTER] requirements"; right hand sided latent variable: "Psychic stress [ENTER] of the work"):

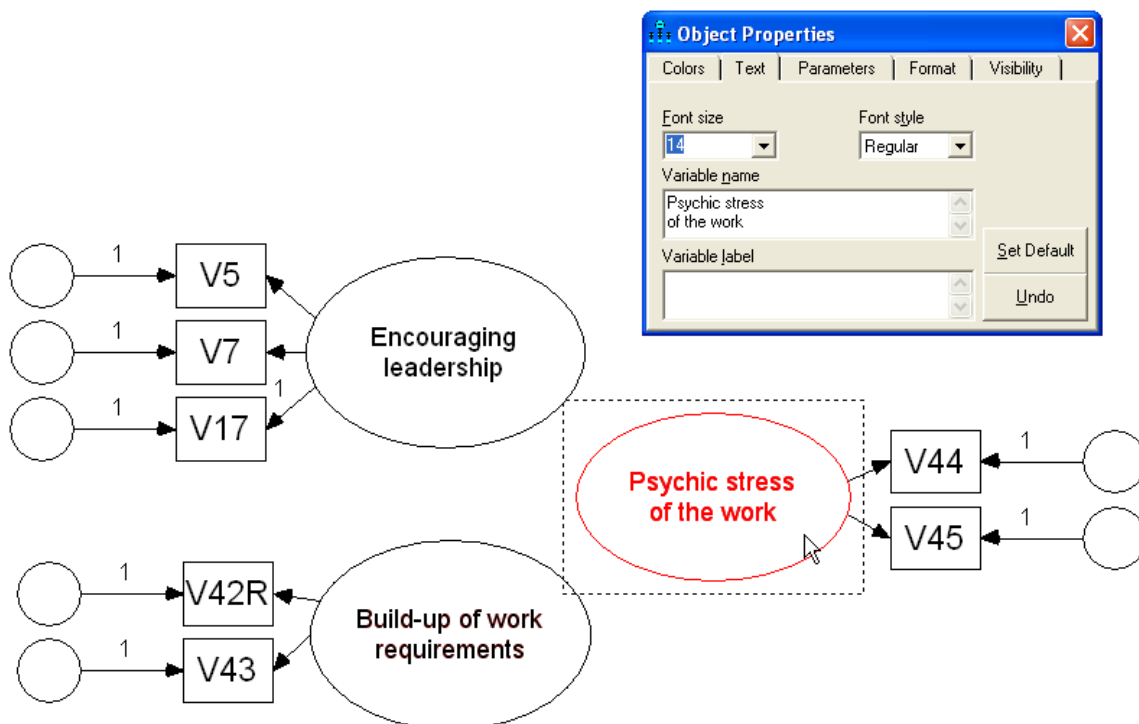

30. Use **Draw covariances (F6)** tool  to draw a double headed arrow between "Encouraging leadership" and "Build-up of work requirements" latent variables.

The two latent variables are allowed to correlate in the model. This decision is based on a theoretical assumption.

31. Use **Draw paths (F5)** tool  to draw a single headed arrow from both aforementioned latent variables to "Psychic stress of the work" variable:

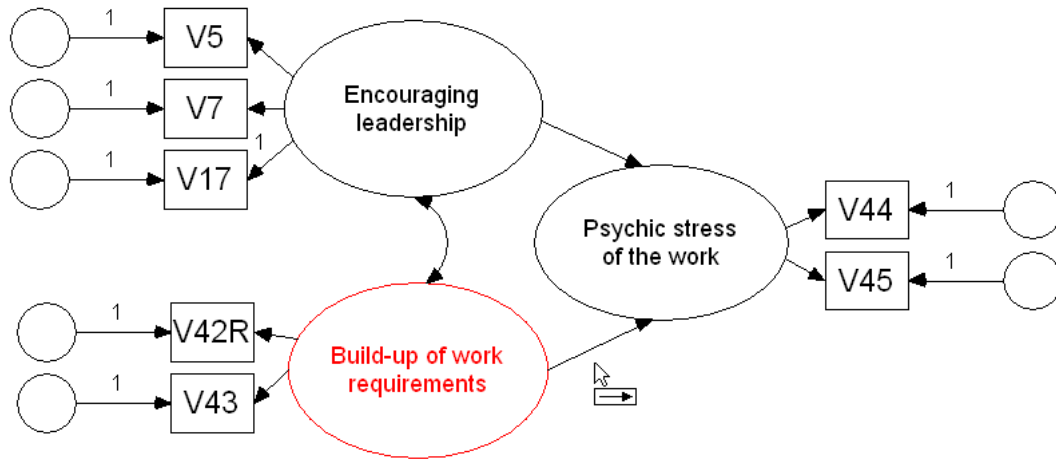

32. Select **Add a unique variable ..** button  and add an error source to the "Psychic stress of the work" variable by clicking it *once* with the tool:

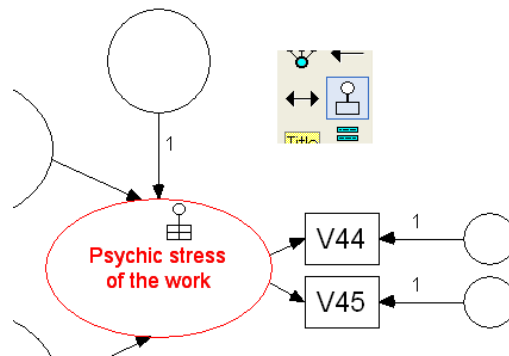

33. Deselect the **Add a unique variable ..** button .

34. Name all the empty circles (i.e., error sources) in the model by double clicking one of them and then filling the **Object properties** window's **Variable Name** field as follows:

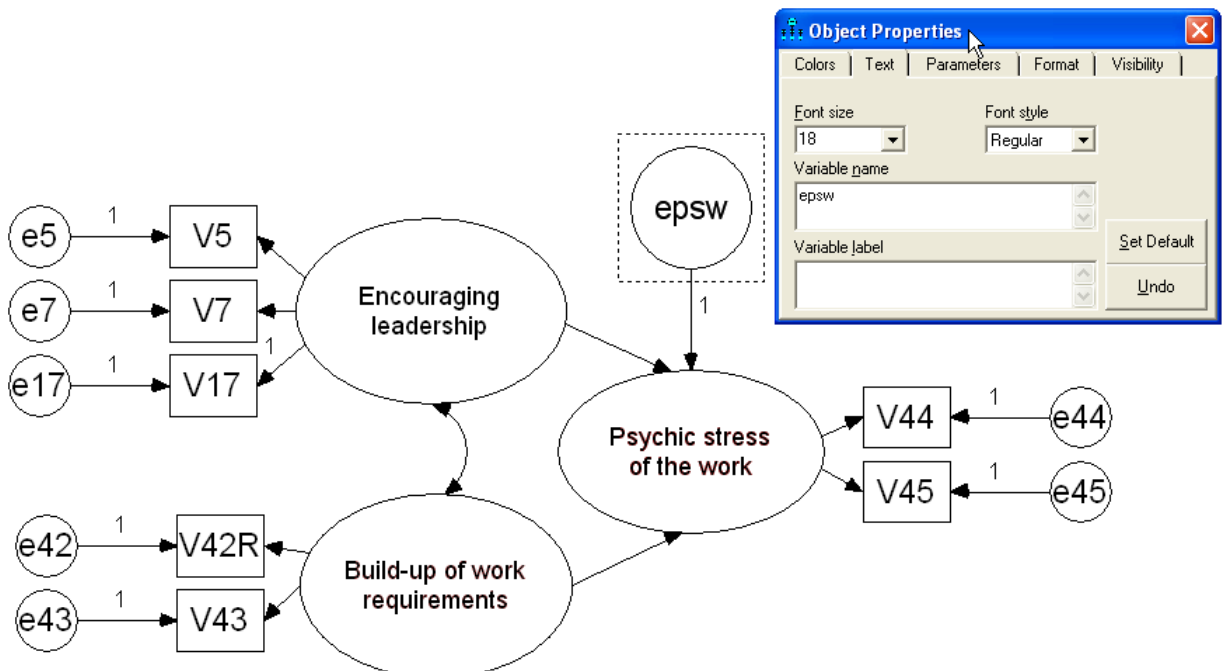

35. Using the same **Object properties** window, make sure that at least *one* arrow departing from each variable has a regression weight of "1".

This procedure helps the model to become *identifiable* and indicates which one of the observed variables is the "number one operationalization" of the latent variable.

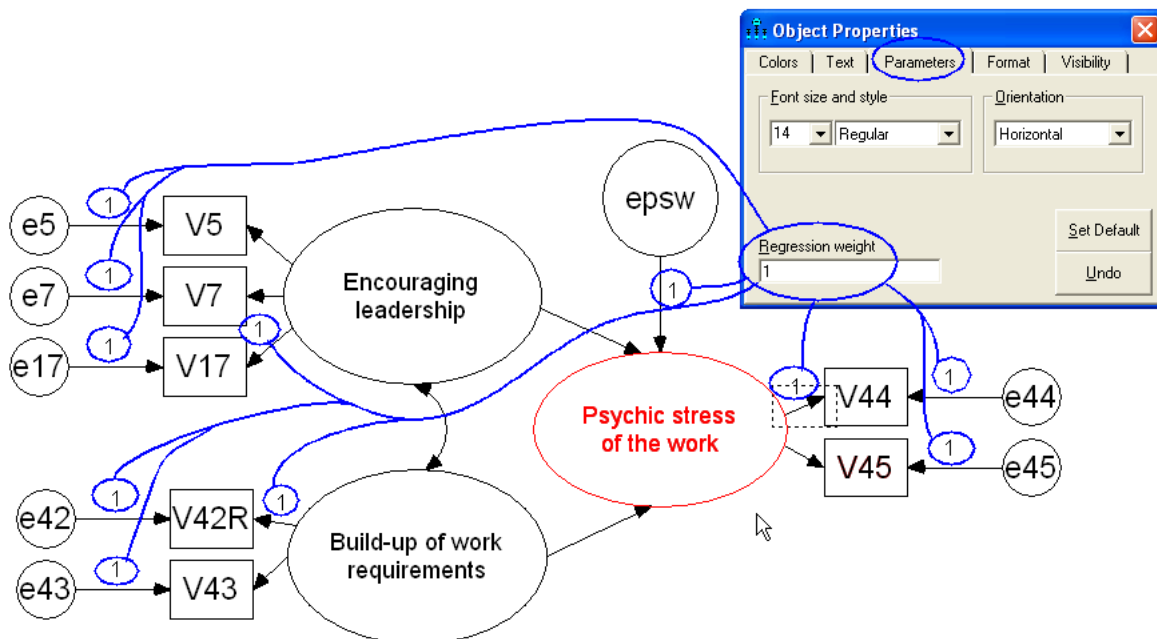

36. Now the model is ready and it should look like this:

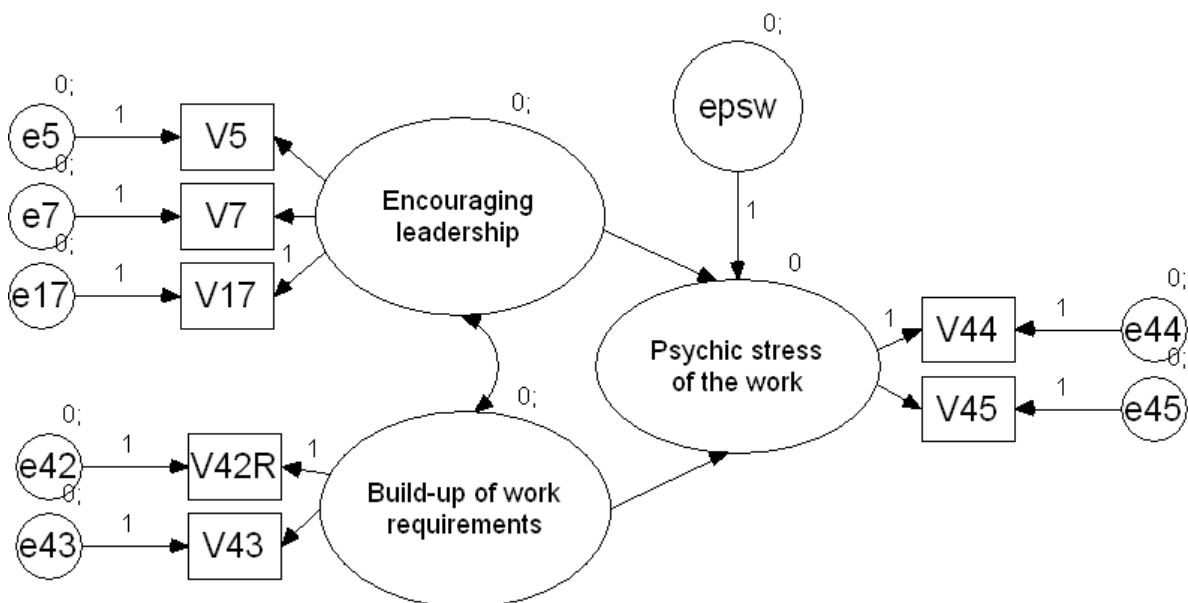

37. Save the model: **File – Save** (Ctrl + S).

38. Click the **Calculate estimates** (Ctrl+F9) button  to perform the analysis of the model with the data.



39. Click the **View the output path diagram** button to see the results of the analysis.

If the button is not enabled, the analysis was not conducted for some (usually technical) reason. The three most common error sources are: 1) The model is not identifiable (Solution: You need to fix one or more parameter constraints, see section 27 on page 13); 2) You have given the same name for two or more error sources and the program gives a following error message: “There is more than one variable named xx” (Solution: Check that each circle has a unique name, e.g., “e1”, “e2”, etc.); 3) There are one or more accidentally drawn objects inside or *outside* the drawing area resulting for an error message, for example, “1 variable is unnamed” (Solution: Click the **Resize the path**

diagram .. tool button  to fit all the objects on the drawing area and remove any unnecessary objects.

40. Now you are able to examine both unstandardized and standardized estimates of the model:

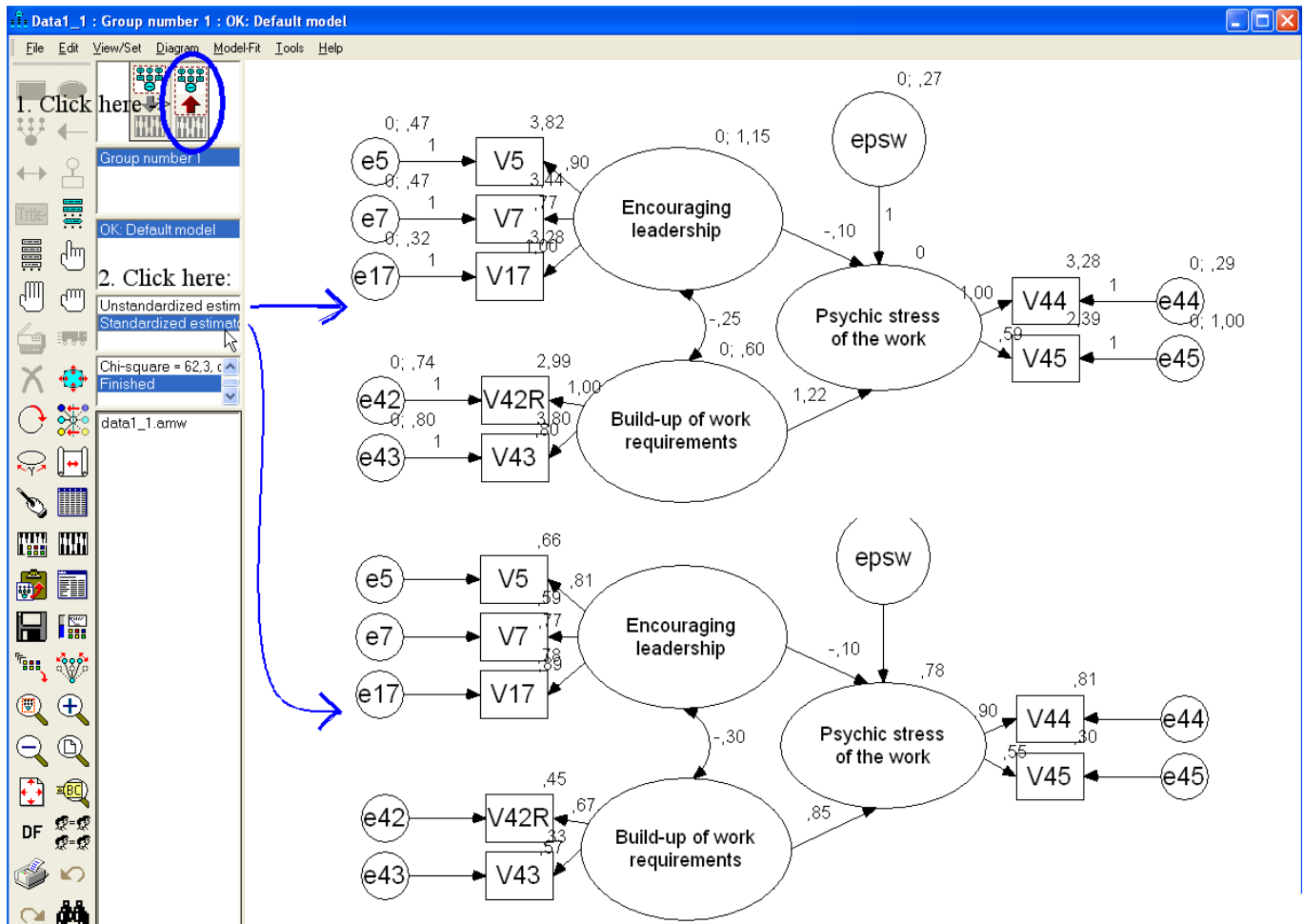

41. Select the **Standardized estimates** view.

42. Standardized estimates view shows the explained variance (squared multiple correlation) of the model ($R^2 = .785 \approx 79\%$):

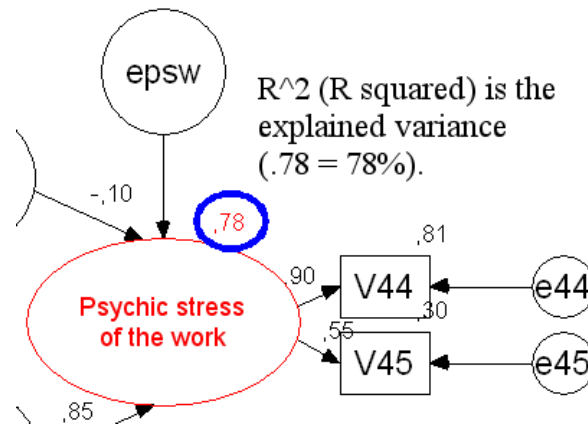

43. Standardized values of an observed indicator v5 and its error variance are explained as follows:

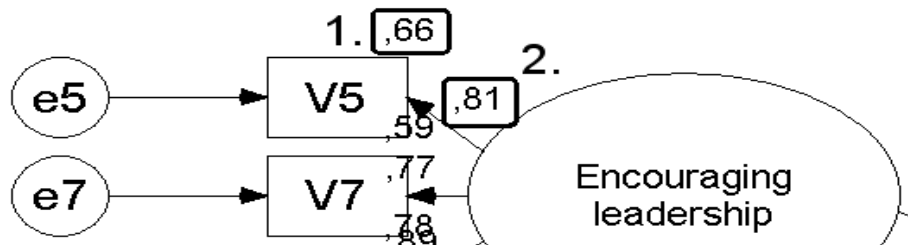

- (1) Squared multiple correlation (SMC) of v5 is 66 per cent.
- (2) The standardized total (direct and indirect) effect of "Encouraging leadership on" v5 is .81. That is, due to both direct (unmediated) and indirect (mediated) effects of "Encouraging leadership" on v5, when "Encouraging leadership" goes up by 1 standard deviation, v5 goes up by 0.81 standard deviations.

44. Consider, on the basis of the standardized estimates of the model, how the two IV's explain the DV, psychic stress of the work:

- Best predictor for *Psychic stress of the work* is _____ $r =$ _____
- Second best predictor for *Psychic stress of the work* is _____ $r =$ _____

45. How well the two IV's predict the DV? (Squared Multiple Correlations)?

- $Smc_{data1_1} =$ _____ that equals to _____ per cent.

46. Select the **Unstandardized estimates** view.

47. Unstandardized values of an observed indicator v5 and its error variance are explained as follows:

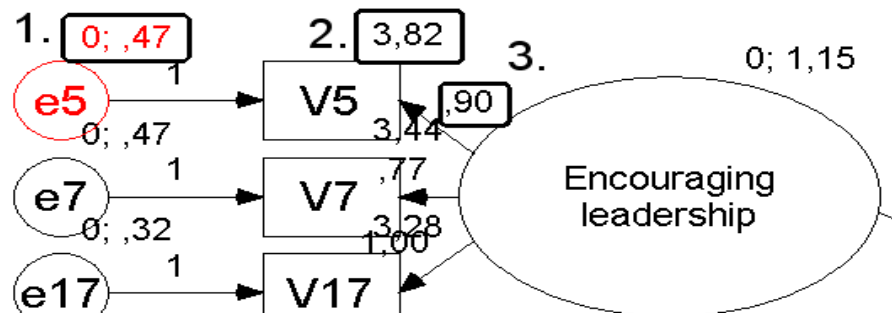

(1) Mean of error (e5) for the v5 is 0 and the variance is 0.47.

(2) The mean of 3.82 is an estimation of the population mean of the observed variable (v5) under the hypothesis that the model is correct.

(3) The total effect (combined direct and indirect effect) of "Encouraging leadership" on v5 is .90. When "Encouraging leadership" goes up by 1 measurement scale value, v5 goes up by 0.90 scale values (here the scale is from 1 to 5).

48. Click **View text (F10)** button  to proceed to a more detailed level of model analysis. The most important headings in the text output window are as follows:

- **Notes for Model.** Notes display if the model was fitted to the data successfully ("Minimum was achieved"). Also degrees of freedom (more you fix the values, more limited the analysis becomes and the *df* is getting smaller), Chi square (χ^2) value, and the models probability level (so called *p* value) is reported.

According to Arbuckle and Wothke (1999), *P* is the probability of getting as large a discrepancy as occurred with the present sample (under appropriate distributional assumptions and assuming a correctly specified model). That is, *P* is a "*p* value" for testing the hypothesis that the model fits perfectly in the population.

P value should usually be greater than pre-set probability level (usually .05). If the value is .05 or less, the departure of the data from the model is significant at the .05 level (model does not fit into data). However, the appropriateness of hypothesis testing in model fitting, even when the necessary distributional assumptions are met, is routinely questioned.

One approach to model selection employs statistical hypothesis testing to eliminate from consideration those models that are inconsistent with the available data. Hypothesis testing is a widely accepted procedure and there is a lot of experience in its use. However, its unsuitability as a device for model selection was pointed out early in the development of analysis of moment structures (Jöreskog, 1969). It is generally acknowledged that most models are useful approximations that do not fit perfectly in the population. In other words, the null hypothesis of perfect fit is not credible to begin with and will in the end be accepted only if the sample is not allowed to get too big. (Arbuckle & Wothke, 1999.)

- **Estimates.** These indices show the unstandardized (original scale) and standardized (normalized scale where $M = 0.0$ and $SD = 1.0$) regression estimates (the same values are presented in the graphical path models above). For example, *unstandardized* estimate between *Encouraging leadership* and *Psychic stress of the work* are interpreted as follows: When Encouraging leadership goes up by 1, Psychic stress of the work goes down by .10.

When we examine the Regression Weights table a bit closer, we see from the “P” column that the probability of getting a critical ratio (C.R. is calculated by dividing the regression weight estimate by the estimate of its standard error $z = -.104/.063 = -1.651$) as large as -1.651 in absolute value is $p = .099$. In other words, the regression weight for Encouraging leadership in the prediction of Psychic stress of the work *is not significantly different from zero* at the .05 level (two-tailed). On the other hand, the similar p value for the difference between Build-up of work requirements and Psychic stress of the work is significantly different from zero ($p < .001$). The last part of the estimates, Squared multiple correlation ($R^2 = .785$), shows how much the two predictors (IV’s) explain the variance of the DV, *Psychic stress of the work*, that is, 79 per cent.

- **Model Fit.** There is such a great number of indices available that next we will consider only the most important ones to report on a scientific work that involves structural equation modeling.
 - **TLI, NNFI** (Tucker-Lewis Index, Non-Normed Fit Index) compare the proposed model to a baseline model that all other models should be expected to exceed (Hair, Anderson, Tatham & Black, 1995, p. 685). Values close to one indicate a very good fit.
 - **CFI, RNI** (Comparative fit index, Relative Noncentrality Index) are similar measures to TLI and RNI. Values close to one indicate a very good fit.
 - **NFI** (Normed Fit Index) is also similar to preceding model fit indices, telling how big discrepancy there is between the model being evaluated (default model) and the baseline model (terribly fitting ‘independence model’). According to Bentler & Bonett (1980, p. 600), referring to both the NFI and the TLI, “Since the scale of the fit indices is not necessarily easy to interpret (e.g., the indices are not squared multiple correlations), experience will be required to establish values of the indices that are associated with various degrees of meaningfulness of results. In our experience, models with overall fit indices of less than .90 can usually be improved substantially. These indices, and the general hierarchical comparisons described previously, are best understood by examples.” NFI values close to one indicate a very good fit.
 - **RMSEA** (Root Mean Square Error of Approximation). The RMSEA is designed to evaluate the approximate fit of the model in the population (Kaplan, 2000, p. 112). This indice is getting smaller as the *df* increases. In practice this means that models with large RMSEA values (e.g., 0.12, default model) simplify the reality. This error could be estimated as follows (Browne & Cudeck, 1993; Kaplan, 2000, p. 113): ≤ 0.05 ‘close fit’, $0.05 - 0.08$ ‘fair fit’, $0.08 - 0.10$ ‘mediocre fit’, > 0.10 ‘poor fit’.

RMSEA should always be reported with *confidence intervals* (C.I.) that in AMOS describe the population RMSEA for the default model (your model) with approximately 90 per cent confidence. However, with C.I., certain statistical distribution assumptions should be met. First, observations must be independent. Second, the IV must meet multivariate normal distribution requirement.

49. Table 4 shows how these indices are reported in practice.

The upper section of the table, *measures of absolute fit*, determine the degree to which the model predicts the observed correlation matrix (Hair et al., 1995, p. 683).

First, relative χ^2 is calculated by dividing the χ^2 with *df*, resulting in 5.66. Usually values less than five are considered adequate (Marsh & Hocevar, 1985). However, some researchers argue that the value should be less than two (Byrne, 1989).

Second, the RMSEA estimate of .10 is in the upper bound of the mediocre fit level (.08 - .10), indicating that the model over simplifies the reality. Also, the upper limit of the 90 per cent confidence interval (.12) supports this assumption.





The lower section of the table, *incremental fit measures*, compares the proposed model (default model) to a baseline model (independence model) that all other models should be expected to exceed. Both NFI and CFI are above the expected .90 level (Tucker & Lewis, 1973). For example, the *NFI* value of .945 is calculated with the minimum discrepancy values (CMIN) of the default and independence models ($NFI = 1 - 62.250 / 1129.189 = .945$). It shows that the tested model has a discrepancy that is 94.5 per cent of the way between the (terribly fitting) independence model and the (perfectly fitting) saturated model.

Table 4. Goodness-of-fit Values of the Exercise 2 Model

Growth-oriented atmosphere questionnaire (22 items)	Finnish polytechnic institute of higher education students (<i>n</i> = 447)	
<i>Measures of Absolute Fit</i>		
χ^2	62.25	
<i>df</i>	11	
χ^2 / df	5.66	
<i>p</i>	< .001	
<i>RMSEA</i>	.102	
90 per cent C.I.	.078	.128
<i>Incremental Fit Measures</i>		
<i>NFI</i>	.945	
<i>CFI</i>	.953	
<i>TLI</i>	.882	

50. Save the model by selecting **File – Save**.

51. Run **Windows Explorer** and examine the AMOS files in your work folder (e.g., c:\temp\sem):

 A9EB55EA.AmosP	1 KB	AMOSP File
 data1_1.AmosOutput	105 KB	AMOSOUTPUT File
 data1_1.amp	6 KB	AmosTableViewer.Document
 Data1_1.AmosTN	7 KB	AMOSTN File
 data1_1.amw	8 KB	Amos Graphics Document

- data1_1.amw AMOS Graphics file. This is the model you just drew, so do not loose it!
- data1_1.amosOutput AMOS Text Output file. Here you have the analysis results in a text file. These you may easily reproduce by estimating the model once again.

Exercise 2a

1. Save the “data1_1.amw” model as “data1_2.amw”.

We use the same data file (data1.sav), but add one predictor to the model, namely *rewarding of know-how*.

2. Modify the “data1_2.amw” model as follows:

Before you start the work, note two things: First, due to limitation of maximum number of observed variables (8) in AMOS student version, we need to drop one *encouraging leadership* indicator, namely v7, from the model. Second, all the IV's in the model are allowed to correlate (Hint: Select all IV's and use **Tools – Macros – Draw covariances**).

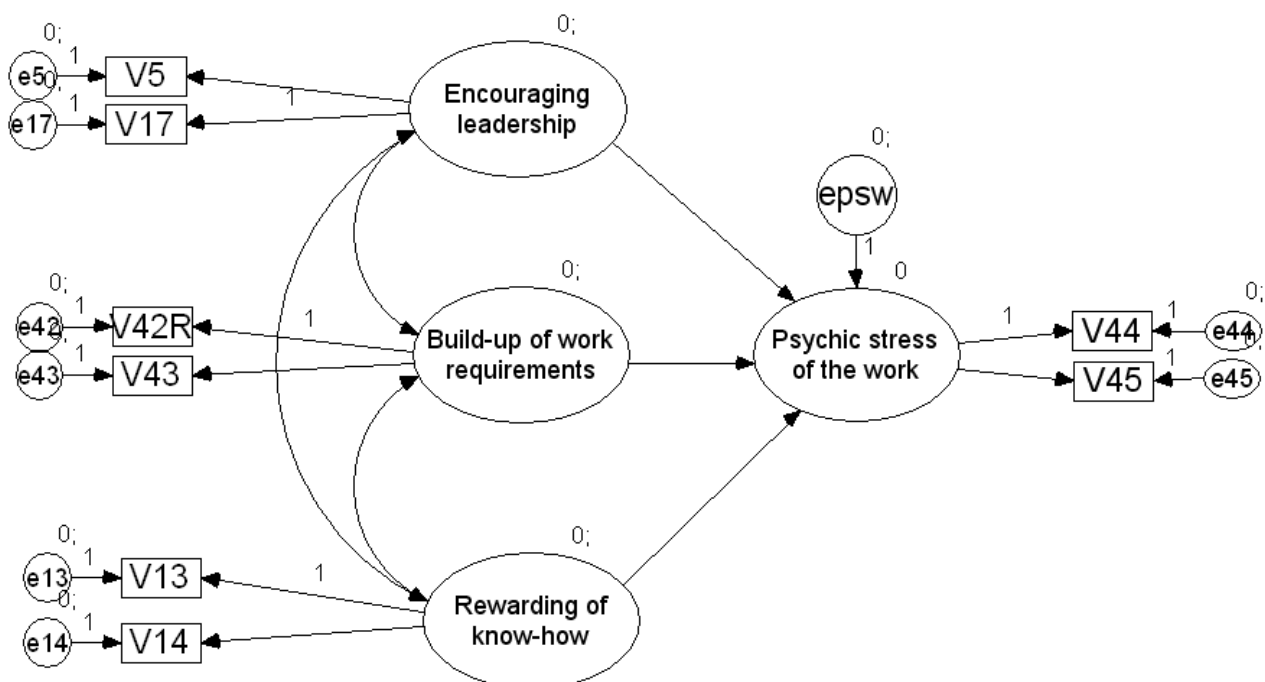

Figure 2. Measurement model 1b of predictors of psychic stress of the work in Finnish polytechnic institute of higher education (structural equation model 1b)

3. Before calculating the estimates, consider *in theory* should the new IV behave as a negative or positive promotor for psychic stress of the work?

The task is easier if you first read the item descriptions of v13 and v14 in Table 1.

4. Click the **Calculating the estimates (Ctrl+F9)** button.

If the **View the output path diagram** –button (i.e., the ‘red arrow’ button) does not activate, please consult section 34 in page 14.

5. How do the three IV's differ as predictors for the DV?

- The first (strongest) predictor for *Psychic stress of the work* is _____ $r =$ _____
- The second predictor for *Psychic stress of the work* is _____ $r =$ _____
- The third predictor for *Psychic stress of the work* is _____ $r =$ _____

6. How well the three IV's predict the DV? (Squared Multiple Correlations)

$Smc_{data1_2} =$ _____ that equals to _____ per cent.

7. Complete the following sentences:

- When *Encouraging leadership* goes up by 1, *Psychic stress of the work* goes up / down by _____.
- When *Build-up of work requirements* goes up by 1, *Psychic stress of the work* goes up / down by _____.
- When *Rewarding of know-how* goes up by 1, *Psychic stress of the work* goes up / down by _____.

8. Complete the following Table 5.

Table 5. Comparison of the Goodness-of-fit Values of the Exercise 2 and 2a Models

Growth-oriented atmosphere questionnaire	Finnish polytechnic institute of higher education students (<i>n</i> = 447)	
	Model 1	Model 1a
<i>Measures of Absolute Fit</i>		
χ^2	62.25	
<i>df</i>	11	
χ^2 / df	5.66	
<i>p</i>	> .001	
<i>RMSEA</i>	.102	
90 per cent C.I.	.078	.128
<i>Incremental Fit Measures</i>		
<i>NFI</i>	.945	
<i>CFI</i>	.953	
<i>TLI</i>	.882	

9. Compare the goodness-of-fit values of the models 2 and 2a, which model fits better to the data? Why?

Table 5. Cross-validation of the Model 1 with Two Different Samples from the same Domain

	Finnish polytechnic institute of higher education students	
	Model 1 (<i>n</i> = 447)	Model 1 (<i>n</i> = 332)
Growth-oriented atmosphere questionnaire		
<i>Measures of Absolute Fit</i>		
χ^2	62.25	
<i>df</i>	11	
χ^2 / df	5.66	
<i>p</i>	> .001	
<i>RMSEA</i>	.102	
90 per cent C.I.	.078	.128
<i>Incremental Fit Measures</i>		
<i>NFI</i>	.945	
<i>CFI</i>	.953	
<i>TLI</i>	.882	

References

- Arbuckle, J., & Wothke, W. (1999). *Amos 4.0 User's Guide*. Chicago: SPSS Inc.
- Bentler, P. M., & Bonett, D. G. (1980). Significance tests and goodness of fit in the analysis of covariance structures. *Psychological Bulletin*, 88, 588–606.
- Bollen, K. (1989). *Structural Equations with Latent Variables*. New York: John Wiley & Sons.
- Byman, R. (2001). *Curiosity and Exploration: Four Dimensions of Gender-Free Exploration - A Methodological Example Study*. Retrieved from <http://www.edu.helsinki.fi/oppimateriaalit/byman2003.htm>.
- Hair, J. F., Anderson, R. E., Tatham R. L., & Black, W. C. (1995). *Multivariate Data Analysis*. Fourth edition. Englewood Cliffs, NJ: Prentice Hall.
- Jöreskog, K. G. (1969). A general approach to confirmatory maximum likelihood factor analysis. *Psychometrika*, 34, 183–202.
- Kaplan, D. (2000). *Structural Equation Modeling*. Thousand Oaks: Sage.
- Marsh, H. W., & Hocevar, D. (1985). Application of confirmatory factor analysis to the study of self-concept: First- and higher-order factor models and their invariance across groups. *Psychological Bulletin*, 97, 562–582.
- Muthén, L., & Muthén, B. (2000). *MPLUS User Manual*. Los Angeles: Muthén & Muthén.
- Nokelainen, P. (2007). *Introduction to Structural Equation Modeling*. Retrieved from: http://www.uta.fi/laitokset/aktk/lectures/sem_en/.
- Nokelainen, P., & Ruohotie, P. (1999). Structural Equation Modeling in Professional Growth Research. In P. Ruohotie, H. Tirri, P. Nokelainen, & T. Silander (Eds.), *Modern Modeling of Professional Growth, vol. 1* (pp. 121-154). Hämeenlinna, Finland: RCVE.
- Nokelainen, P., & Ruohotie, P. (2009). Non-linear Modeling of Growth Prerequisites in a Finnish Polytechnic Institution of Higher Education. *Journal of Workplace Learning*, 21(1), 36-57.
- Ruohotie, P. (1996). Professional Growth and Development. In K. Leithwood et al. (Eds.), *International Handbook of Educational Leadership and Administration* (pp. 419-445). Dordrecht: Kluwer Academic Publishers.
- Ruohotie, P., Nokelainen, P., & Tirri, H. (2002, April). *Visualization of Growth-oriented Atmosphere*. Paper presented at the Annual Meeting of American Educational Research Association, New Orleans, U.S.
- Raykov, T., & Marcoulides, G. A. (2000). *A First Course in Structural Equation Modeling*. Mahwah, NJ: Lawrence Erlbaum Associates.
- Schumacker, R. E., & Lomax, R. G. (2004). *A Beginner's Guide to Structural Equation Modeling*. Second edition. Mahwah, NJ: Lawrence Erlbaum Associates.